



MINI EXCAVATOR RANGE

SY35U

SY35U mini excavator is designed to help you work efficiently while maximizing your jobsite productivity. The 3.86 ton excavator has many features to help operators achieve the balance of power, smoothness, fuel efficiency and speed.

- » Yanmar customized engine.
- » European imported hydraulic system
- » The excavator's tail does not exceed the track suitable for narrow spaces
- » Strengthened undercarriage for stable operation
- » Open one cover and reach to all parts, making the maintenance more convenient



SANY

SY35U-TIER 4F (EU)

 OPERATING WEIGHT:

3860kg

 ENGINE MODEL:

**Yanmar 3TNV88F
-ESSY**

 WARRANTY:

5 Year / 5,000 Hour

WWW.SANYHM.COM.AU

QUALITY CHANGES THE WORLD

SY35U DIMENSIONS & SPECIFICATIONS

OVERALL DIMENSIONS

A	Transport length	4915mm
B	Transport width	1720mm
C	Transport height	2515mm
D	Upper width	1550mm
E	Blade height	350mm
F	Tail swing radius	860mm
G	Min. ground clearance	295mm

WORKING RANGE

a	Max. digging height	4855mm
b	Max. dumping height	3460 mm
c	Max. digging depth	3105 mm
d	Max. vertical digging depth	2700 mm
e	Max. digging reach	5465 mm
f	Min. swing radius	2475 mm
g	Height at min.swing radius	3685mm
h	Max. ground clearance of blade up	375mm
i	Max. depth of blade down	370mm

MACHINE PARAMETERS

Operating weight	3860 kg
Engine model	Yanmar 3TNV88F-ESSY
Rated power	18.2/2200 kW/ rpm
Max. torque	94.5/1200NN.m./ rpm
Displacement	1.642L
Emission standard	Tier 4f
Travel speed	4.4/2.4kw/h
Swing speed	9rpm
Gradeability	58%
Ground pressure	32kPa
Bucket digging force	30.4kN
Arm digging force	18.2kN
Fuel tank capacity	40L
Hydraulic tank capacity	40L
Bucket capacity	0.12 m ³
Track gauge	1420mm
Roller gauge	1670mm
Boom length	2540 mm
Arm length	1400 mm

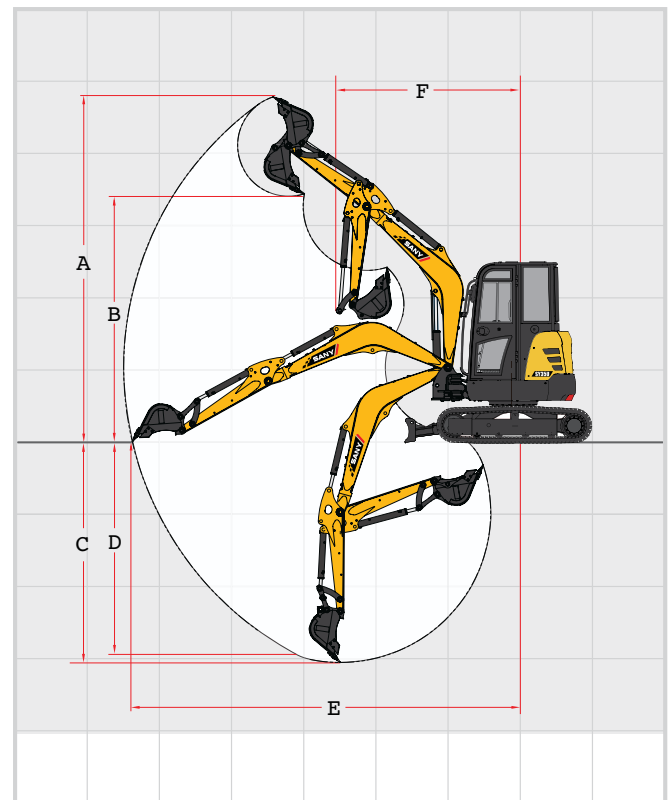
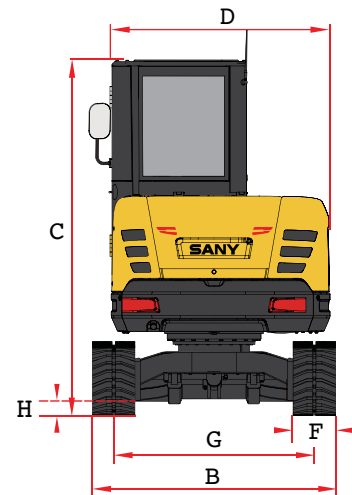
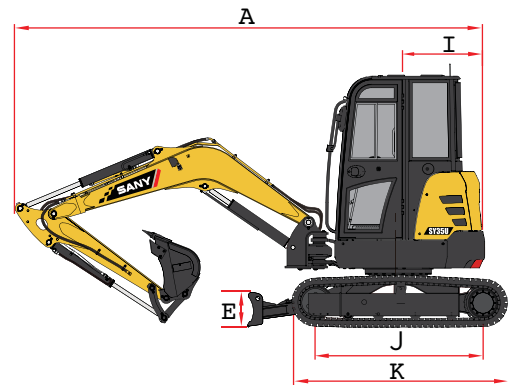

Not all products are available in all markets. Under our policy of continuous improvement, Sany reserve the right to change specifications and design without prior notice. The illustrations do not necessarily show the standard version of the machine.

SANY HEAVY MACHINERY (AUSTRALIA)

21 EFFICIENT DRIVE, TRUGANINA VIC 3029

PHONE 0400 724 483 WWW.SANYHM.COM.AU



SANY